

PA-25

Data Sheet



Control Ability	Multiple Actuators
Input Voltage	12VDC
Output Power	12VDC
Current	15A (Each Channel)
Kit Includes	2 Hand Remotes, 2 Actuator Wire Harnesses, 1 Power wire Harness, 1 Control Box, Batteries
Remote Functions	Up, Down, Pause (Momentary & Non-Momentary)
Remote Battery Type	2x CR2016 3V Lithium Cell
Size (L x H x W)	5.9" x 1.3" x 3.9"
Weight	1.10 lbs
Warranty	18 Months



Dimensions

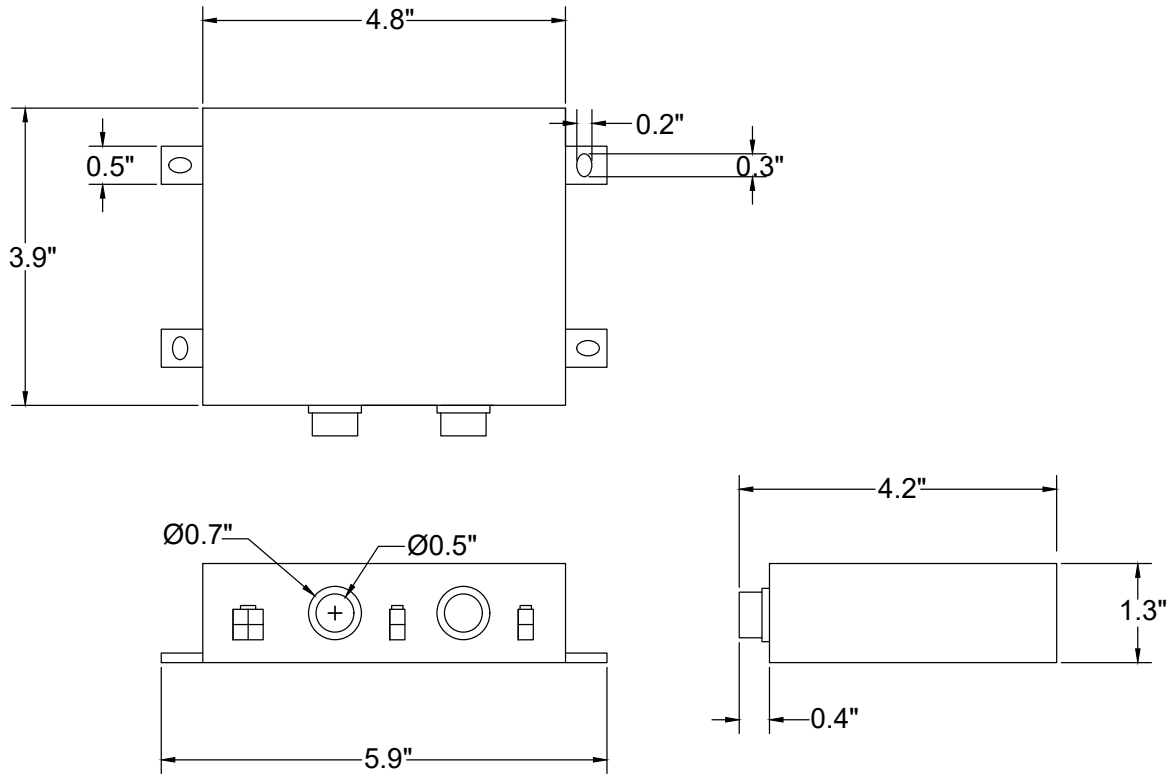

Wiring Diagram

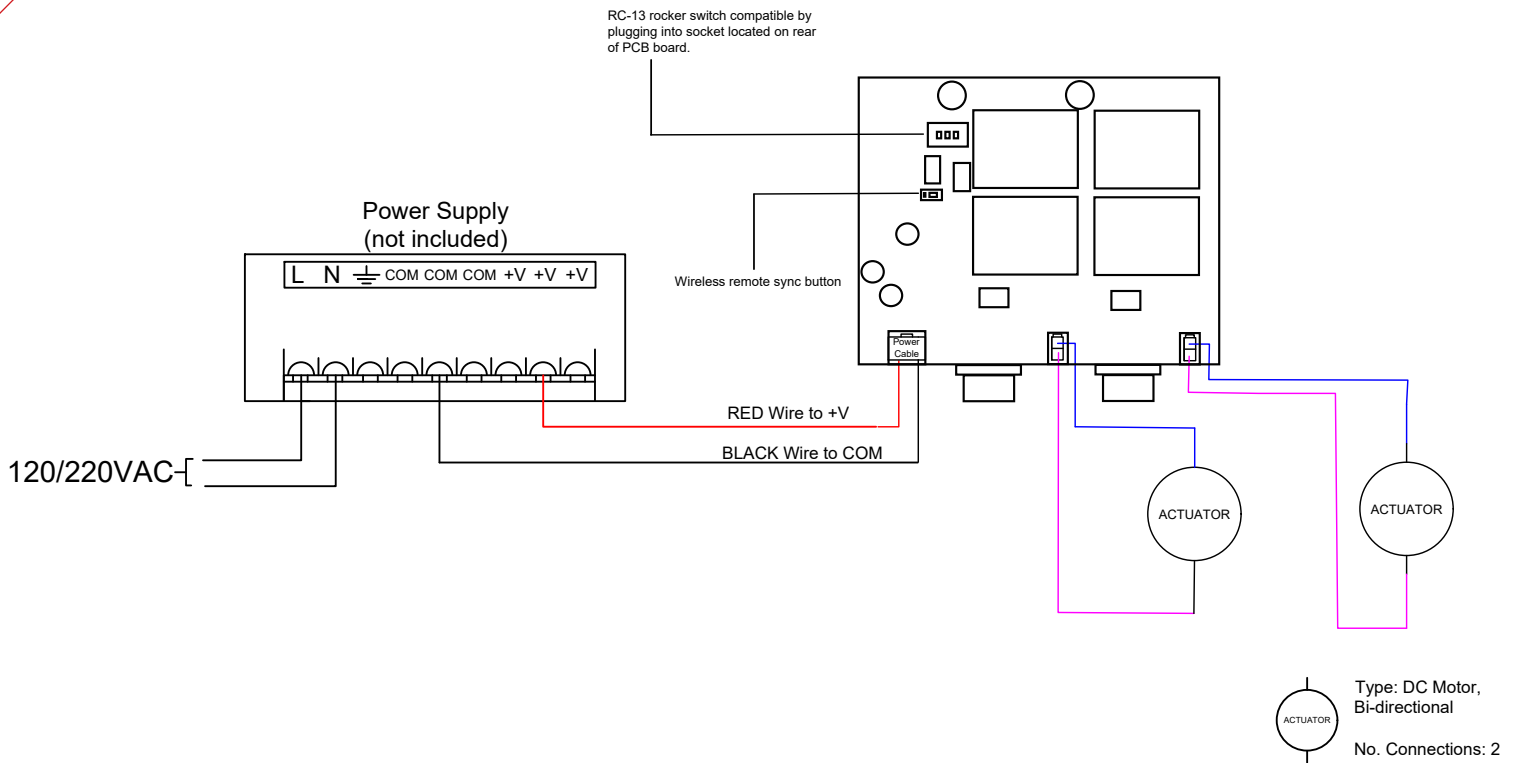



Momentary/Non-Momentary Mode

Momentary Mode

- Ensure the Jumper S1 on the PCB is connected
- Hold UP to extend the actuator, let go to stop the actuator
- Hold DOWN to retract the actuator, let go to stop the actuator

Non-Momentary Mode

- Ensure the Jumpers S1 on the PCB is disconnected
- Press UP to extend the actuator, Press UP again to stop the actuator
- Press DOWN to retract the actuator, Press DOWN again to stop the actuator
- If DOWN is pressed while the actuator is extending, it will reverse direction and begin to retract



Remote Synchronization Process

- Open the control box and press the white button. the blue LED will turn on
- Press any button on the remote and the LED will turn off
- The remote is now saved to the control box
- A maximum of two remotes can be saved to one control box